

8/10/13 kVA

GUARDIAN® SERIES Residential Standby Generators Air-Cooled Gas Engine

INCLUDES:

- True Power™ Electrical Technology
- Two Line LCD Multilingual Digital Evolution™ Controller (English/Spanish/French/Portuguese)
- Electronic Governor
- External Main Circuit Breaker, System Status & Maintenance Interval LED Indicators
- Sound Attenuated Enclosure
- Flexible Fuel Line Connector
- Composite Mounting Pad
- Natural Gas or LP Gas Operation
- 1 Year Limited
- Compatible with RTSI Transfer Switches Only

Standby Power Rating

Model 006269-0 (Steel - Bisque) - 8 kVA 50 Hz
Model 006270-0 (Steel - Bisque) - 10 kVA 50 Hz
Model 006271-0 (Steel - Bisque) - 13 kVA 50 Hz



FEATURES

- **INNOVATIVE DESIGN & PROTOTYPE TESTING** are key components of Generac's success in "IMPROVING POWER BY DESIGN." But it doesn't stop there. Total commitment to component testing, reliability testing, environmental testing, destruction and life testing, allows you to choose Generac with the confidence that these systems will provide superior performance.
- **TEST CRITERIA:**
 - ✓ PROTOTYPE TESTED
 - ✓ MOTOR STARTING ABILITY
 - ✓ SYSTEM TORSIONAL TESTED
- **SOLID-STATE, FREQUENCY COMPENSATED VOLTAGE REGULATION:** This state-of-the-art power maximizing regulation system is standard on all Generac models. It provides optimized FAST RESPONSE to changing load conditions and MAXIMUM MOTOR STARTING CAPABILITY by electronically torque-matching the surge loads to the engine.
- **SINGLE SOURCE SERVICE RESPONSE** from Generac's dealer network provides parts and service know-how for the entire unit, from the engine to the smallest electronic component.

8/10/13 kVA

Engine

- Generac (OHVI) design
Maximizes engine “breathing” for increased fuel efficiency. Plateau honed cylinder walls and plasma moly rings helps the engine run cooler, reducing oil consumption resulting in longer engine life.
- “Spiny-lok” cast iron cylinder walls
Rigid construction and added durability provide long engine life.
- Electronic ignition/spark advance
These features combine to assure smooth, quick starting every time.
- Full pressure lubrication system
Pressurized lubrication to all vital bearings means better performance, less maintenance and longer engine life. Now featuring up to a 2 year/200 hour oil change interval.
- Low oil pressure shutdown system
Shutdown protection prevents catastrophic engine damage due to low oil.
- High temperature shutdown
Prevents damage due to overheating.

Generator

- Revolving field
Allows for a smaller, light weight unit that operates 25% more efficiently than a revolving armature generator.
- Skewed stator
Produces a smooth output waveform for compatibility with electronic equipment.
- Displaced phase excitation
Maximizes motor starting capability.
- True Power Technology
Less than 5% total harmonic distortion (THD)
- Automatic voltage regulation
Regulates the output voltage to $\pm 1\%$ prevents damaging voltage spikes.

Evolution™ Controls

- Auto/Manual/Off illuminated buttons
Selects the operating mode and provides easy, at-a-glance status indication in any condition.
- Sealed, raised buttons
Smooth, weather-resistant user interface for programming and operations.
- Utility voltage sensing
Constantly monitors utility voltage, setpoints 60% dropout, 80% pick-up, of standard voltage.
- Utility interrupt delay
Prevents nuisance start-ups of the engine, adjustable 2-1500 seconds from the factory default setting of 5 seconds by a qualified dealer.
- Engine warm-up
Ensures engine is ready to assume the load, setpoint approximately 5 seconds.
- Engine cool-down
Allows engine to cool prior to shutdown, setpoint approximately 1 minute.
- Programmable seven day exerciser
Operates engine to prevent oil seal drying and damage between power outages by running the generator for 12 minutes every week.
- Smart battery charger
Delivers charge to the battery only when needed at varying rates depending on outdoor air temperature.
- Main line circuit breaker
Protects generator from overload.
- Electronic governor
Maintains constant 50 Hz frequency.

Unit

- SAE weather protective enclosure
Sound attenuated enclosure ensures quiet operation and protection against mother nature, withstanding winds up to 150mph. Hinged key locking roof panel for security. Lift-out front for easy access to all routine maintenance items. Electrostatically applied textured epoxy paint for added durability.
- Enclosed critical grade muffler
Quiet, critical grade muffler is mounted inside the unit to prevent injuries.
- Small, compact, attractive
Makes for an easy, eye appealing installation.

Installation System

- 1 ft (305 mm) flexible fuel line connector
Easy installation.
- Composite mounting pad

8/10/13 kVA

Generator

Model	006269-0 (8 kVA)	006270-0 (10 kVA)	006271-0 (13 kVA)
Rated Maximum Continuous Power Capacity (LP)	8,000 VA*	10,000 VA*	13,000 VA*
Rated Maximum Continuous Power Capacity (NG)	7,000 VA**	10,000 VA**	13,000 VA**
Rated Voltage	220	220	220
Rated Maximum Continuous Load Current – 220 Volts, Single Phase (LP/NG)	36.4/31.8	45.5/45.5	59/59
Main Line Circuit Breaker	40 Amp	50 Amp	63 Amp
Phase	1	1	1
Number of Rotor Poles	2	2	2
Rated AC Frequency	50 Hz	50 Hz	50 Hz
Power Factor	1	1	1
Battery Requirement (not included)	Group 26R, 12 Volts and 525 CCA Minimum		
Unit Weight (lb/kg)	387/175.4	435/197.3	471/213.6
Dimensions (L x W x H) in/mm	48 x 25 x 29/1218 x 638 x 732		
Sound output in dB(A) at 23 ft (7 m) with generator operating at normal load**	60	60	60

Engine

Type of Engine	GENERAC OHVI V-TWIN	GENERAC OHVI V-TWIN	GENERAC OHVI V-TWIN
Number of Cylinders	2	2	2
Displacement	530 cc	992 cc	992 cc
Cylinder Block	Aluminum w/ Cast Iron Sleeve	Aluminum w/ Cast Iron Sleeve	Aluminum w/ Cast Iron Sleeve
Valve Arrangement	Overhead Valve	Overhead Valve	Overhead Valve
Ignition System	Solid-state w/ Magneto	Solid-state w/ Magneto	Solid-state w/ Magneto
Governor System	Electronic	Electronic	Electronic
Compression Ratio	9.5:1	9.5:1	9.5:1
Starter	12 Vdc	12 Vdc	12 Vdc
Oil Capacity Including Filter	1.7 qt/1.6 L	1.9 qt/1.8 L	1.9 qt/1.8 L
Operating rpm	3,000	3,000	3,000
Fuel Consumption			
Natural Gas	ft ³ /hr. (m ³ /hr)		
	1/2 Load	83 (2.35)	124 (3.51)
	Full Load	138 (3.91)	195 (5.52)
Liquid Propane	ft ³ /hr (gal/hr) [l/hr]		
	1/2 Load	32.8 (0.90) [3.41]	42.8 (1.18) [4.45]
	Full Load	55.2 (1.52) [5.74]	70 (1.92) [7.28]

Note: **Fuel pipe must be sized for full load.** Required fuel pressure to generator fuel inlet at all load ranges - 3.5-7" water column (7-13 mm mercury) for natural gas, 10-12" water column (19-22 mm mercury) for LP gas.

Outputs are based upon values @ 1000 Btu per cubic feet with NG and 2500 Btu per cubic feet with LP

@ 37.26 Megajoules per cubic meter with NG and 93.15 Megajoules per cubic meter with LP

Controls

2-Line Plain Text Multilingual LCD Display	Simple user interface for ease of operation.
Mode Buttons:	Automatic Start on Utility failure. 7 day exerciser.
Manual	Start with starter control, unit stays on. If utility fails, transfer to load takes place.
Off	Stops unit. Power is removed. Control and charger still operate.
Ready to Run/Maintenance Messages	Standard
Engine Run Hours Indication	Standard
Programmable start delay between 2-1500 seconds	Standard
Utility Voltage Loss/Return to Utility Adjustable	From 140-156 V/175-198 V
Future Set Capable Exerciser/Exercise Set Error Warning	Standard
Run/Alarm/Maintenance Logs	50 Events Each
Engine Start Sequence	Cyclic cranking: 16 sec on, 7 rest (90 sec maximum duration).
Starter Lock-out	Starter cannot re-engage until 5 sec after engine has stopped.
Smart Battery Charger	Standard
Charger Fault/Missing AC Warning	Standard
Low Battery/Battery Problem Protection and Battery Condition Indication	Standard
Automatic Voltage Regulation with Over and Under Voltage Protection	Standard
Under-Frequency/Overload/Stepper Overcurrent Protection	Standard
Safety Fused/Fuse Problem Protection	Standard
Automatic Low Oil Pressure/High Oil Temperature Shutdown	Standard
Overcrank/Overspeed/rpm Sense Loss Shutdown	Standard
High Engine Temperature Shutdown	Standard
Internal Fault/Incorrect Wiring Protection	Standard
Common External Fault Capability	Standard
Field Upgradable Firmware	Standard

**Sound levels are taken from the front of the generator. Sound levels taken from other sides of the generator may be higher depending on installation parameters. Rating definitions - Standby: Applicable for supplying emergency power for the duration of the utility power outage. No overload capability is available for this rating. (All ratings in accordance with BS5514, ISO3046, DIN6271 and AS/NZS CISPR 12:2009). * Maximum wattage and current are subject to and limited by such factors as fuel Btu content, ambient temperature, altitude, engine power and condition, etc. Maximum power decreases about 3.5 percent for each 1,000 (304.8 meters) feet above sea level; and also will decrease about 1 percent for each 6 °C (10 °F) above 16 °C (60 °F).

8/10/13 kVA

available accessories

Model #	Product	Description
006212-0	Cold Weather Kit	If the temperature regularly falls below 32 °F (0 °C), install a cold weather kit to maintain optimal battery and oil temperatures. Kit consists of a battery warmer and oil filter heater with built-in thermostats.
005839-0	Fascia Base Wrap Kit	The fascia base wrap snaps together around the bottom the new air-cooled generators. This offers a sleek, contoured appearance as well as offering protection from rodents and insects by covering the lifting holes located in the base.
005703-0	Paint Kit	If the generator enclosure is scratched or damaged, it is important to touch-up the paint to protect from future corrosion. The paint kit includes the necessary paint to properly maintain or touch-up a generator enclosure.
006483-0 - 8 kVA 006484-0 - 10 & 13 kVA	Scheduled Maintenance Kit	Generac's scheduled maintenance kits provide all the hardware necessary to perform complete routine maintenance on a Generac automatic standby generator.

dimensions & UPCs

Dimensions shown are approximate. Refer to installation manual for exact dimensions. DO NOT USE THESE DIMENSIONS FOR INSTALLATION PURPOSES.

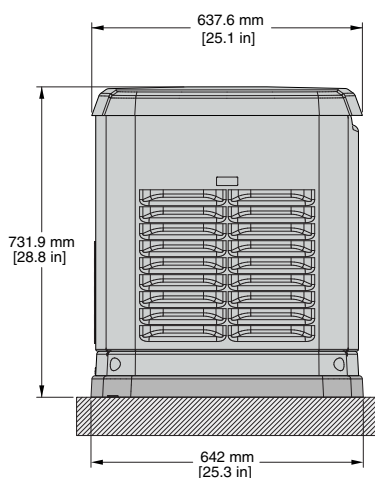

LEFT SIDE VIEW

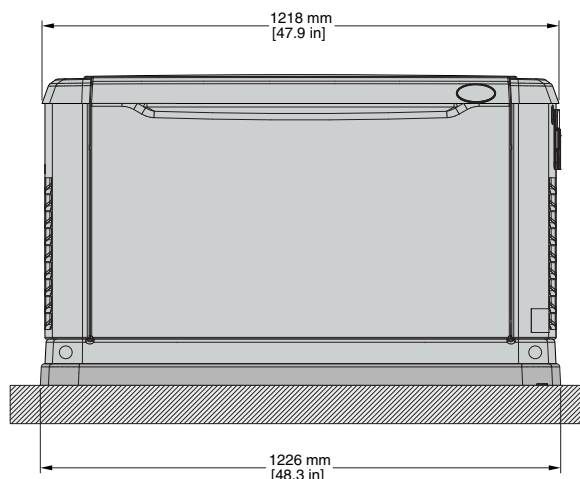

FRONT VIEW

Model	UPC
006269-0	696471062694
006270-0	696471062700
006271-0	696471062717